

## Preventing performance drops of coal mills due to high moisture content

P.F. Odgaard, J. Stoustrup, and B. Mataji

**Abstract**—Coal mills pulverize and dry the coal dust before it is blown into the furnace in coal-fired power plants. The coal mills can only deliver the requested coal flow if certain conditions are fulfilled. These are normally considered as constraints on individual variables. However, combinations of more than one variable might cause problems even though these individually variables are in an acceptable region. This paper deals with such a problem. The combination of a high load of the power plant, a large load change and high moisture content in the coal, can force the coal mill into a state where coal is accumulated instead of being blown into the furnace. This paper suggests a simple method for preventing the accumulation of the coal in the mill, by limiting the requested coal flow considering the coal moisture content and the temperature outside the mill.

### I. INTRODUCTION

Coal mills are used in coal-fired power plants to pulverize the coal before it is blown into the furnace. Inside the coal mill the coal is pulverized by a number of rollers. The hot primary air used in the furnace is let through the coal mill with two purposes: to evaporate the moisture content from the coal dust, and to lift the dried coal particles into the furnace. The temperature of the hot primary air is manipulated such that the temperature of the coal dust at the classifiers in the coal mill is kept at  $100^{\circ}\text{C}$ . If the mill is operating with a combination of high coal flows, a large load change and very high moisture content of the coal at the same time, consequently it is not always possible to keep the temperature at  $100^{\circ}\text{C}$ . In this case a constraint on the maximal heating energy, which can be delivered to the coal mill by the primary air flow, is violated. This constraint on maximal energy in the primary airflow can be transformed to a constraint on the mill load in terms of the requested coal flow. This means that the moisture cannot be evaporated from the coal dust, resulting in the coal particles being too heavy to be lifted up into the furnace. Instead the wet coal dust will accumulate in the mill.

The conventional control strategy of the furnace will as a consequence request more coal dust from the coal mills, which results in even more coal being accumulated in the coal mill, and thereby worsen the problem. The problem might be even worse, if the accumulated coal dust starts to

be blown into the furnace. In some cases with high plant loads, this increase in the coal dust flow might overheat the plant. A highly costly trip or shutdown of the plant is consequently necessary.

One way to solve this problem would be to redesign the control system, to a multi-variable controller taking the constraints into account, e.g. a model predictive control scheme. Examples of such designs for power plants can be seen in [1] and [2]. However, in some cases it is preferable to keep the existing control structure with a few modification, which prevents the system from violating the constraints, as the violation is a rare occurring event, and performance of the system is not an issue during violation as long as the plant can continue the production with a few modifications.

This paper presents a method for preventing the specific problem occurring. A table of maximal coal flows is computed depending of moisture content and other non-controlled variables. The maximal coal flow is subsequently used to limit the requested coal flow, and thereby avoid the described problem in occurring.

The paper presents the coal mill, the structure of the proposed control scheme, the scheme, simulations of the scheme compared with control without prevention of the constraint problem, and finally a conclusion is drawn.

### II. THE COAL MILL

The work presented in this paper, is based on a Babcock MPS 212 coal mill used at a Danish power plant. However, the method proposed in the paper is so generic that it can be applied to other types of coal mills. The coal mill is illustrated in principle in Fig. 1. The coal is fed to the coal mill through the central inlet pipe. The coal is pulverized on the rotating grinding table by the rollers. The pulverized coal is then blown up and the hot primary air evaporates the moisture content. The primary air flow is formed by a mixing of cold outdoor air and outdoors air heated by hot flue gas from the furnace. The ratio of these air flows are used to control the temperature of the primary air flow. Coal particles that during the pulverizing process have been minimized sufficiently will pass through the classifier and out through the outlet pipes into the furnace.

#### A. Control and measurements

References to coal flow and primary air flow are given by the power plant master controller, as well as rotational speed of the classifiers. The temperature of the primary air is used to control the temperature in the coal mill at the

P.F. Odgaard is at KK-Electronic a/s, Pontoppidanstræde 101, DK-9220 Aalborg East, Denmark, pfo@kk-electronic.dk, he was at Department of Electronic Systems, Aalborg University during the research for this paper.

J. Stoustrup is at Section of Automation and Control, Department of Electronic Systems, Aalborg University, Fredrik Bajers Vej 7C, DK-9220 Aalborg East, Denmark, jakob@esn.aau.dk

B. Mataji is at Dong Energy A/S, Kraftværksvej 53, DK-7000 Fredericia, Denmark, bamat@dongenergy.dk

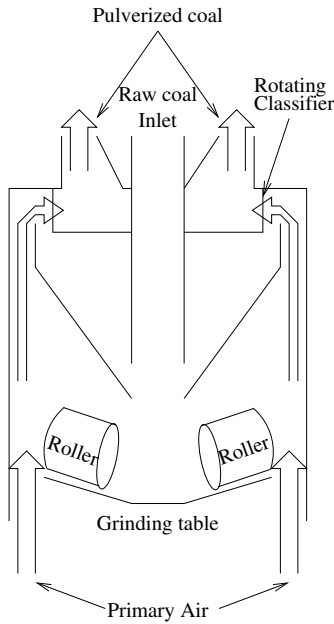

Fig. 1. An illustration of the coal mill.

classifiers. The temperature controller is often required to keep temperature constant at  $100^{\circ}\text{C}$  in order to evaporate the moisture content in the coal. A coal mill is a harsh environment to perform measurements in. Consequently not all the variables are measurable. E.g. the actual coal flows in and out of the coal mill are measured, but the input coal flow is requested as a reference signal by the plant controller. However, the primary air flow and temperature can be measured, as well as the coal dust temperature. The moisture content can be estimated using an observer, see [3].

### III. SOLUTION STRATEGY

The proposed solution sets up limits on the existing requested coal flow given certain conditions as illustrated in Fig. 2. The system to be considered consists of the coal mill, which pulverizes and dries the coal dust before it is blown into the furnace. The coal flow leaving the coal mill for the furnace is denoted  $\dot{m}_{c,out}(t)$ . In the furnace the coal is burned. Thermal energy released from the burned coal is used to produce steam used to drive a turbine, which produces electricity. In order to control the plant a large number of control loops are formed. In this perspective two of these are of interest. These are the load controller and the primary air temperature controller. The load controller leads the furnace to produce a requested volume of steam. In order to do so, the input coal flow is controlled,  $\dot{m}_{c,in}(t)$ , as well as the primary air flow,  $\dot{m}_{pa}(t)$ . These two flows are, in this control strategy, linearly dependent. The objective of the temperature controller is to keep the temperature of the coal dust in the mill,  $T(t)$ , at the evaporation temperature ( $100^{\circ}\text{C}$ ). This is done by manipulating the temperature of

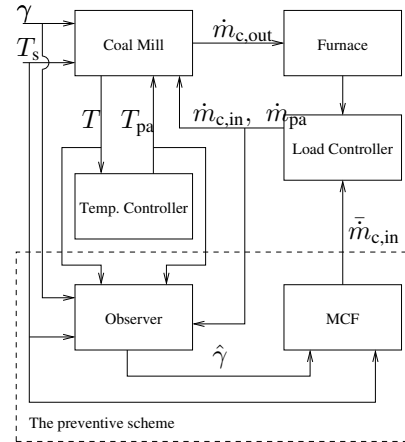

Fig. 2. The structure of the preventive scheme.

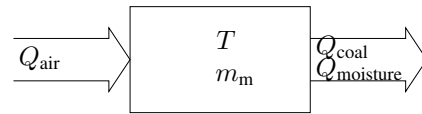

Fig. 3. An illustration of energy balance in the coal mill, where  $T$  is the temperature in the mill,  $Q_{\text{air}}$  is the energy in the primary air flow,  $Q_{\text{coal}}$  is the energy in the coal flow, and  $Q_{\text{moisture}}$  is the energy in the coal moisture.

the primary air,  $T_{pa}(t)$ . This control loop, suppresses among others two important disturbances, the moisture content,  $\gamma(t)$  which is not measurable but observable, the estimated moisture content is denoted  $\hat{\gamma}(t)$ , and the temperature outside the coal mill,  $T_s(t)$  which is measured.

The proposed scheme consists of two parts, an energy model of the coal mill and an observer. Such an observer is presented in [3].

The core part of this scheme is the Maximal Coal Flow computer (MCF), which computes the maximal coal flow the coal mill can heat, and lift into the furnace given the specific conditions on moisture content etc. This maximal coal flow is denoted  $\bar{m}_{c,in}$ . This maximal flow is fed to the load controller, and is used as a constraint on the requested coal flow. If the coal flow is limited this information should be forwarded to the scheme requesting the specific energy production of the plant, such that these coal flow requests can be adjusted accordingly.

### IV. ENERGY BALANCE MODEL OF THE COAL MILL

A simple energy balance model of the coal mill is derived based on [4]. In this model the coal mill is seen as one body with the mass  $m_m$ , as illustrated in Fig. 3, in which  $T(t)$  is the temperature in the mill,  $Q_{\text{air}}(t)$  is the energy in the primary air flow,  $Q_{\text{coal}}(t)$  is the energy in the coal flow, and  $Q_{\text{moisture}}(t)$  is the energy in the coal moisture. The specific heat capacity of the mill is denoted  $C_m$ . Even though this assumption is only entirely true for steady state, it is assumed in this paper for simplifying the model. The

energy balance is given by (1).

$$m_m \cdot C_m \cdot \dot{T}(t) = Q_{\text{air}}(t) - Q_{\text{coal}}(t) - Q_{\text{moisture}}(t). \quad (1)$$

The heating and evaporation of the moisture in the coal are modeled by a combined heating coefficient. The objective of the temperature controller is to keep the temperature at  $100^\circ\text{C}$ . The latent energy of the evaporation dominates the energy required for a few degrees heating of the moisture. The combined heat coefficient,  $H_{\text{st}}$ , is defined as follows  $H_{\text{st}} = C_w + L_{\text{steam}}/100$ , where  $C_w$  is the specific heat of the water, and  $L_{\text{steam}}$  is the latent heat. This combined heat coefficient does not deal with the fact that the specific heat of water and steam are different. However, the model error due to heat of steam to a couple of degrees above  $100^\circ\text{C}$  is negligible in this context.

The dynamic non-linear model is subsequently given by

$$\begin{aligned} m_m C_m \dot{T}(t) = & \dot{m}_{\text{pa}}(t) C_{\text{air}} (T_{\text{PA}}(t) - T(t)) \\ & + (\dot{m}_{\text{c,in}}(t) + \dot{m}_{\text{c,a}}(t)) \cdot C_c \cdot (T_s - T(t)) \\ & + \gamma(t) \cdot (\dot{m}_{\text{c,in}}(t) + \dot{m}_{\text{c,a}}(t)) \cdot C_w \cdot T_s \\ & - \gamma(t) \cdot (\dot{m}_{\text{c,in}}(t) + \dot{m}_{\text{c,a}}(t)) \cdot H_{\text{st}} \cdot T(t), \end{aligned} \quad (2)$$

where:  $T(t)$  is the mill temperature at the classifier,  $\dot{m}_{\text{pa}}(t)$  is the primary air mass flow in and out of the mill,  $C_{\text{air}}$  is the specific heat of air,  $T_{\text{PA}}(t)$  is the temperature of the inlet primary air,  $\dot{m}_{\text{c,in}}(t)$  is the coal mass flow into the mill,  $\dot{m}_{\text{c,a}}(t)$  is the coal mass flow accumulated in the mill,  $C_c$  is the specific heat of the coal,  $T_s$  is the surrounding temperature,  $\gamma(t)$  is the ratio of moisture in the coal,  $C_w$  is the specific heat of the moisture.

#### A. Modeling accumulation of coal due to moisture content

The accumulation of the coal dust, is assumed to depend on the temperature drop of the coal dust.  $\dot{m}_{\text{c,a}}(t)$  is modeled as the product of the input coal flow times the difference between  $T(t)$  and  $100^\circ\text{C}$  times a constant. This value is subsequently low-pass filtered with a first order filter, see (3).

$$\ddot{m}_{\text{c,a}}(t) = \tau \cdot \dot{m}_{\text{c,a}}(t) + \alpha \cdot \dot{m}_{\text{c,in}}(t) \cdot (T(t) - 100), \quad (3)$$

where  $\dot{m}_{\text{c,in}}(t)$  is the input coal flow,  $\tau$  and  $\alpha$  are two model parameters. The coal flow out of the mill,  $\dot{m}_{\text{c,out}}(t)$ , is modeled as (4).

$$\dot{m}_{\text{c,out}}(t) = \dot{m}_{\text{c,in}}(t) - \dot{m}_{\text{c,a}}(t) \quad (4)$$

#### B. Parameter identification

All parameters in this model are found in data sheets except  $m_m \cdot C_m$ ,  $\tau$  and  $\alpha$  which are identified based on measurements of a step response on plant load given by the requested coal flow to the coal mill, see Fig. 4. In this figure the moisture content is as well shown during the load change. In this data sequence coal was accumulated inside the coal mill due to an increase in the moisture content. The

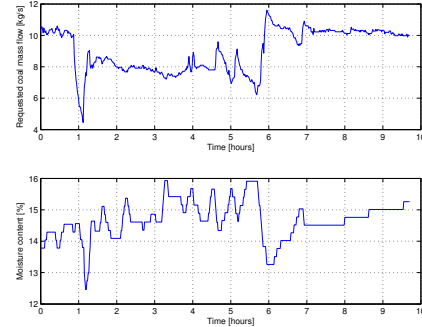

Fig. 4. A plot of the requested coal flow and moisture content.

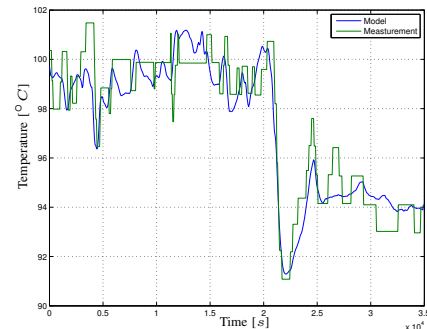

Fig. 5. A plot of the non-linear model response with measurements of a step response on the coal mill, and temperature drop due to high moisture content and large load change.

model response is compared with measurements in Fig. 5. From this figure it can be seen that the responses of the model is quite similar to the large dynamical changes as the measurements show. However, it is difficult to validate the details in the response due to the way the signals are sampled. A dead-band of one per cent is applied to these measurements meaning that the signals shall have changes of a given size before this change is sampled. The model is subsequently discretized before further usage.

#### C. Control

In the simulations  $T_{\text{pa}}(t)$  is controlled by a PID-like controller similar to the conventional used ones. The parameters are found based on the ones from the power plant in question. The plant controller provides  $\dot{m}_{\text{pa}}(t)$  by a linear relation to  $\dot{m}_{\text{c,in}}(t)$ .

#### V. THE PROPOSED SCHEME

The principles in the scheme are to limit the requested coal flow such that it does not cause any violations of the control signal constraints. This information on limiting the coal flow is of course required to be fed throughout the power plant control hierarchy, since this proposed scheme would limit the possible power plant load. In this work the maximal coal flow would be computed depending on both moisture content,  $\gamma[n]$ , as well as the outside temperature,  $T_s[n]$ . The scheme limits the maximal coal flow as well

as the maximal coal flow gradient. The output will be a function of maximal allowed coal flows, a function computing the maximal load change given start and stop coal flows, in addition to the moisture content and outside temperature. The maximal coal flow is computed by a static energy balance, and the maximal gradient is computed using a dynamic energy balance.

#### A. The static maximal coal flow

The maximal coal flow,  $MCF(\gamma, T_s)$ , can be found as the largest coal flow for which the energy in the primary air flow is larger than the energy required to heat the coal flow and heat and evaporate the coal moisture content, see (5).

$$\begin{aligned} \dot{m}_{pa}[n]C_{air}(T_{PA}[n] - T[n]) > \\ \dot{m}_{c,out}[n]C_c \cdot (-T_s + T[n]) \\ - \gamma[n]\dot{m}_{c,out}[n]C_w \cdot T_s \\ + \gamma[n]\dot{m}_{c,out}[n]H_{st} \cdot T[n]. \end{aligned} \quad (5)$$

The requested value of  $T[n]$  is  $100^\circ C$  and  $T_{PA}[n]$  takes its maximal possible value. The maximal value of  $T_{PA}[n]$  depends on the requested coal flow. Based on experimental data this relation is approximated with linear function. I.e.  $T_{PA}[n] = a_1 \cdot \dot{m}_{c,in}[n] + b_1$ . The primary air flow is controlled in relationship with the coal dust flow, in the way that  $\dot{m}_{pa}[n]$  depends linearly on  $\dot{m}_{c,in}[n]$ , i.e.  $\dot{m}_{pa}[n] = a_2 \cdot \dot{m}_{c,in}[n] + b_2$ . This means that (5) can be rewritten to (6).

$$\begin{aligned} (a_2 \cdot \dot{m}_{c,in}[n] + b_2)C_{air} \cdot (a_1 \cdot \dot{m}_{c,in}[n] + b_1) \geq \\ \dot{m}_c[n]C_c \cdot (100 - T_s) \\ - \gamma[n]\dot{m}_c[n]C_w \cdot T_s \\ + \gamma[n]\dot{m}_c[n]H_{st} \cdot 100. \end{aligned} \quad (6)$$

(6) can be used to find an expression of  $MCF(\gamma, T_s)$ , see (7), in which the identified parameters are included.

$$MCF(\gamma, T_s) = \frac{-Q_1 - \sqrt{D}}{2 \cdot Q_2}, \quad (7)$$

where

$$D = Q_1^2 - 4 \cdot Q_2 \cdot Q_0, \quad (8)$$

$$Q_2 = 5.0149 \cdot 10^3, \quad (9)$$

$$Q_1 = q_{11} + q_{12} \cdot T_s + q_{13} \cdot T_s \cdot \gamma + q_{14} \cdot \gamma, \quad (10)$$

$$Q_0 = 1.7911 \cdot 10^6, \quad (11)$$

where  $q_{11} = 6.2988 \cdot 10^4$ ,  $q_{12} = 1300$ ,  $q_{13} = 4200$ , and  $q_{14} = 2.7067 \cdot 10^4$ .

Fig. 6 shows MCF computed for  $\gamma[n]$  in the interval from 5% to 30% and  $T_s[n]$  in the interval from  $0^\circ C$  to  $30^\circ C$ . This figure shows an influence from the moisture content as well as a smaller influence from the outside temperature on the maximal feasible coal flow. This scheme designed to

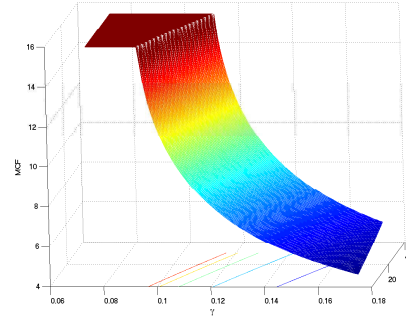

Fig. 6. Plot of MCF depending on  $\gamma$  and  $T_s$

prevent faults due to moisture content can be implemented as the algorithm described in this subsection. The following steps are processed at each sample.

- 1) Estimate the moisture content of the coal,  $\hat{\gamma}[n]$ , and measure the surrounding temperature,  $T_s[n]$ .
- 2) Compute  $\bar{\dot{m}}_{c,in}[n] = MCF(\gamma[n], T_s[n])$  by (7).
- 3)  $\bar{\dot{m}}_{c,in}[n]$  should be set as a constraint on the maximal requested coal flow, and recomputed to a constraint on the maximal load of the plant.

#### B. The maximal coal flow gradient

In order to make the inequality in (5) dynamic two factors are taken into account. The first factor is the energy storage in the mill in terms of the mass of the coal mill. However, this energy storage only influences the energy balance if the temperature variates from  $100^\circ C$ . It is the objective of the primary air controller to keep the mill temperature at  $100^\circ C$ . I.e. due to the controller it is assumed that if this preventive scheme avoids the temperature drops, when the energy storage in the mill can be neglected. The other factor of interest is that the maximal primary air temperature depends on the steam temperature in the furnace, which can be approximated with a first order model. The inequality in (6) is modified to (12-13). If the inequality is true the energy constraint is not violated, meaning it is the objective of the scheme to ensure this inequality to be true.

$$\begin{aligned} (a_2 \cdot \dot{m}_{c,in}[n] + b_2)C_{air} \cdot T_{pa,max}[n] \geq \\ \dot{m}_c[n]C_c \cdot (100 - T_s) \\ - \gamma[n]\dot{m}_c[n]C_w \cdot T_s \\ + \gamma[n]\dot{m}_c[n]H_{st} \cdot 100, \end{aligned} \quad (12)$$

where

$$\begin{aligned} T_{pa,max}[n] = & d_1 \cdot T_{pa,max}[n-1] \\ & + n_1 \cdot (a_1 \cdot \dot{m}_{c,in}[n-1] + b_1), \end{aligned} \quad (13)$$

where the parameters for dynamic model of energy transfer from the furnace are based on experimental data found to:  $d_1 = 0.8454$  and  $n_1 = 0.1546$ .

In order to determine the maximal load change in terms of a maximal load gradient,  $G_{\max}$ , it is necessary to give a description of the requested flow during the load change. In the following it is assumed that the requested coal flow changes from the start coal flow,  $\dot{m}_{c,\text{start}}$ , to the end coal flow,  $\dot{m}_{c,\text{end}}$ , with the constant gradient  $G_{\max}$ . Assuming that a load change takes place from sample 0 to sample  $N$ , a vector of the requested coal flow at each sample,  $\mathbf{m}_{c,\text{in}}$  is defined as

$$\mathbf{m}_{c,\text{in}} = \begin{bmatrix} \dot{m}_{c,\text{start}} \\ \dot{m}_{c,\text{start}} + G_{\max} \cdot t_s \\ \vdots \\ \dot{m}_{c,\text{start}} + G_{\max} \cdot t_s \cdot N \end{bmatrix} \quad (14)$$

The next step is to check if the inequality in (12) is true for the sequence of requested coal flow,  $\mathbf{m}_{c,\text{in}}$ . The initial gradient is the normally used one. From this the maximal gradient can be found using an iterative scheme. This scheme works as follows.

- 1) Set the initial  $G_{\max}$  to the standard max gradient, and compute the vector  $\mathbf{m}_{c,\text{in}}$ , set the step size  $G_{\text{step}} = 0.5 \cdot G_{\max}$ .
- 2) check (12) for all elements in  $\mathbf{m}_{c,\text{in}}$ . If the left side is larger than the right side, the standard maximal gradient is ok, and stops the iteration.
- 3) Find new  $G_{\max} = G_{\max} - G_{\text{step}}$ .
- 4) Compute a new vector  $\mathbf{m}_{c,\text{in}}$ , set the step size  $G_{\text{step}} = 0.5 \cdot G_{\max}$ .
- 5) check (12) for all elements in  $\mathbf{m}_{c,\text{in}}$ . If the left side is larger than the right side, and the minimum difference is smaller than  $\epsilon$  stop the iteration, if the difference is larger than  $\epsilon$ , set  $G_{\max} = G_{\max} + G_{\text{step}}$ , if the left side is not larger for all elements  $G_{\max} = G_{\max} - G_{\text{step}}$ . Jump to step 4.

This proposed scheme is not robust towards any model uncertainties, however, combining it with an prediction scheme taking the model uncertainties into account would solve the robustness issue, such a scheme is proposed in [5]. If such actions are not taken, this proposed scheme could limit the performance of the plant to much. But again these events are rarely occurring, so performance during these events is not important as long as trips are prevented.

## VI. SIMULATIONS

The scheme to prevent the high moisture content causing problems for the power plant, has been tested by simulations on the non-linear model of the coal mill, see Section IV. The simulation for comparing the proposed scheme with the control scheme without handling of the high moisture content has two interesting outputs,  $T[n]$ , which should be at the evaporation temperature ( $100^\circ$ ) and  $\dot{m}_{c,\text{out}}$  which should not be lower than the requested one.

Since the preventing scheme is designed to compute feasible control signals it is expected that when the preventing

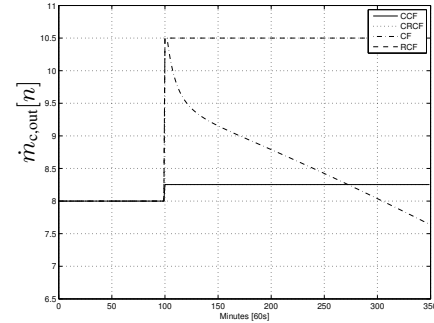

Fig. 7. A plot of  $\dot{m}_{c,\text{out}}[n]$  at  $\gamma = 0.12$  for the handled and non-handled systems. CCF is the handled coal flow, CRCF is the requested handled coal flow, CF is the non-handled coal flow and RCF is the requested non-handled coal flow.

scheme is applied  $T[n]$  would stay at  $100^\circ\text{C}$  while the non-handled system would not keep this temperature as the moisture content increases. It is at least as interesting to investigate if  $\dot{m}_{c,\text{out}}[n]$  for system with the preventive scheme is higher than the non-handled system. This means that in addition to preventing the accumulation of coal in the mill, more coal is actually blown into the furnace, and thereby making a higher load possible than if nothing was done for handling the high moisture content.

The methods were compared at two different settings, a requested coal flow stepping from  $8\text{kg/s}$  to  $10.5\text{kg/s}$  at 100 minutes. For both settings  $T_s[n] = 10^\circ\text{C}$ , the variation between the two settings is the moisture content. Two different ones are chosen which cover the problematic region for the given coal flows. These are  $\gamma = 0.12$  and  $\gamma = 0.15$ .

### A. The first example

The first example with  $\gamma = 0.12$ , is illustrated by two figures. Fig. 7 shows the requested and delivered coal flows for both the handled and non-handled systems. From this figure it can be seen that the handled system keeps the coal flow at the recomputed coal flow, and that the non-handled systems drops from the requested coal flow to below the corrected flow approximately at 170 minutes after the step.

$T[n]$  for both the handled and non-handled system can be seen in Fig. 8. Here the conclusion is as follows: the corrected system keeps  $T[n]$  at  $100^\circ\text{C}$  and the non-handled system can not achieve this, resulting in a drop on  $T[n]$  with a few degrees of the non-handled system.

### B. The second example

The second example with  $\gamma = 0.15$ , is illustrated by two figures. Fig. 9 shows the requested and delivered coal flows for both the handled and non-handled systems. From this figure it can be seen that handled system keeps the coal flow at the lowered requested flow (consequently not differences between CCF and CRCF can be seen), and that the non-handled systems drops below the corrected flow

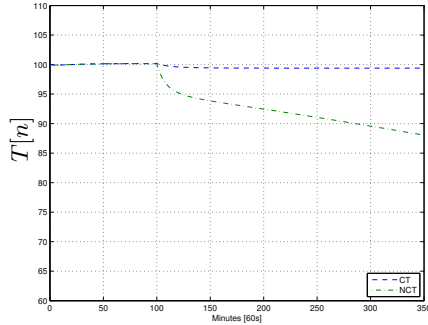

Fig. 8. A plot of  $T[n]$  at  $\gamma = 0.12$ .

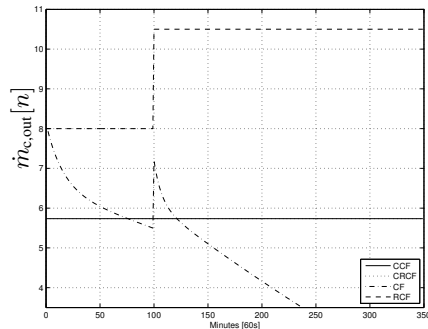

Fig. 9. A plot of  $\dot{m}_{c,out}[n]$  at  $\gamma = 0.15$  for the handled and non-handled systems. CCF is the handled coal flow, CRCF is the requested handled coal flow, CF is the non-handled coal flow and RCF is the requested non-handled coal flow.

approximately 20 minutes after the step. It can be seen that the problem is increasing as the moisture content increases as expected.

$T[n]$  for both the handled and non-handled system can be seen in Fig. 10. Here the conclusion is as follows: the corrected system keeps  $T[n]$  at  $100^\circ\text{C}$  and the non-handled system can not achieve this, resulting in a drop of  $T[n]$  with up to 35 degrees for the non-handled system.

## VII. CONCLUSION

This paper presents a scheme for preventing accumulation of the coal dust in the coal mill due to a combination of a high load requirement, high moisture content and a low outside temperature. The accumulation occurs if the hot drying primary air flow into the coal mill does not contain enough energy to evaporate the coal moisture content. Using an estimation of the coal moisture content the scheme computes the maximal coal flow, which does not lead to a need for more energy for evaporation than possible delivered by the primary air flow. Consequently this means that the energy constraint on the primary air flow is transformed to a constraint on the requested coal flow. The proposed scheme is an add-on to the existing

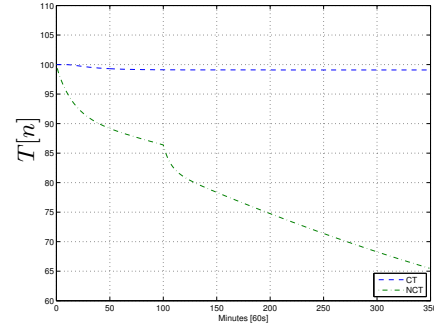

Fig. 10. A plot of  $T[n]$  at  $\gamma = 0.15$ .

controllers, and it is only active during periods where the requested coal flow would lead to a violation of the energy constraint on the primary air flow. I.e. the proposed scheme is a simple alternative to redesigning the control system taking these constraints into account, where the control problem would be required to be treated as a MIMO control problem. The proposed scheme is tested by simulations, which show it is potential for handling the problem of coal accumulation in the mill due to high moisture content.

## VIII. ACKNOWLEDGMENT

The authors acknowledge the Danish Ministry of Science Technology and Innovation, for support to the research program CMBC (Center for Model Based Control), grant no 2002-603/4001-93.

## IX. REFERENCES

- [1] R. Jankowski, P. D. Domanski, and K. Swirski, "Optimization of a coal mill using an mpc type controller," in *2003 ASME International Mechanical Engineering Congress*, Washington, D.C., USA, November 2003, pp. 233–243.
- [2] H. Palizban, P. O’Kelly, and N. Rees, "Practical optimal predictive control of power plant coal mills," in *A Proceedings volume from the IFAC Symposium 2003 Control of Power Plants and Power Systems (SIPOWER’95)*, Cancun, Mexico, December 1995, pp. 269–274.
- [3] P. Odgaard and B. Mataji, "Estimation of moisture content in coal in coal mills," in *Proceedings of IFAC Symposium on Power Plants and Power Systems*, Kananskis, Alberta, Canada, June 2006.
- [4] N. Rees and F. Fan, "Modelling and control of pulverised fuel coal mills," in *Thermal power plant simulation and control*, 1st ed., D. Flynn, Ed. Institution of Electrical Engineers, 2003.
- [5] P. Odgaard, J. Stoustrup, and B. Mataji, "Using dynamical uncertainty models estimating uncertainty bounds on power plant performance prediction," 2007, to appear in proceedings of ECC 2007.