

# Multi-Zone Modeling and Energy Efficient Control of Shopping Center Cooling

Joakim Børllum Petersen\*, Jan Dimon Bendtsen\* and Jakob Stoustrup\*

\*Department of Electronic Systems, Aalborg University, Denmark  
{jbp, dimon, jakob}@es.aau.dk

**Abstract**—In this paper we consider the problem of constructing a dynamical model for shopping center HVAC systems, suitable for proposing new high-level control designs to minimize energy consumption for the entire shopping center. We also propose a preliminary control design, to increase energy efficiency. The specific system considered in this paper, is a small section of a Danish shopping center, including three shops and their joint cooling system. The current control solution is investigated and described.

A dynamical model is constructed as a grey-box RC-equivalent model, a suitable modeling paradigm for control-oriented models that also have to be scalable. Parameters for the model have been identified through a combination of measurement data from several days of live operation and table-lookup, calculating thermal properties based on shop dimensions.

The resulting model is used to propose a preliminary control solution, to increase efficiency by utilizing a higher forward temperature. This is achieved through a control design that seeks to drive valve openings closer to fully open, while still allowing headroom for disturbance rejection. One of the main benefits of this design, is the low implementation barrier, as it does not require alterations to shop-local temperature controllers.

Simulations show that the proposed control solution works as intended, without degrading the performance of the existing shop temperature control.

## I. INTRODUCTION

In Denmark, buildings are responsible for approximately one third of the total energy consumption[1]. Even though energy efficiency continues to improve, the main focus is typically on the building envelope itself, rather than e.g. heating and cooling equipment[2]. The problem with this focus is that energy renovation considering the envelope itself is expensive, in comparison to replacing/updating heating and cooling equipment. There is thus an untapped potential in improving heating and cooling equipment, especially considering older buildings, where an investment in energy renovation of the building envelope can be unattractive from the owner's/operator's point of view.[3][4]

Control applications to reduce energy consumption have been considered in several works, using different approaches, with the majority utilizing predictive control[2]. Given the multi-zone characteristics of many commercial buildings, decentralized and distributed control schemes have been investigated in relatively recent works. In [5], distributed model predictive control is employed to maintain zone temperatures within given comfort requirements, utilizing predictive knowledge of weather and occupancy. Distributed model

predictive control is also used in [6]. A decentralized token-based approach to control and scheduling of Heating Ventilation and Air Conditioning (HVAC) systems in multi-zone buildings is examined in [7].

Generally, the distributed/decentralized solutions suffer a performance loss compared to centralized solutions, but they are scalable, and as such offer numerical robustness when the number of zones considered is relatively large. Another important aspect regarding centralized versus distributed/decentralized is implementation, as it greatly affects the investment size for the owners/operators. A centralized solution could potentially be cheaper given the lower implementation barrier, as no alterations to the individual zones are required.

The work presented in this paper is part of the Energy Technology Development and Demonstration Program (EUDP) project denoted Smart Energy Shopping Centers (SEBUT). SEBUT develops intelligent control systems, knowledge services and tools for energy refurbishment and energy flexibility upgrades of shopping centers in Denmark. Shopping centers are responsible for approximately 25% of the combined energy consumption in the Danish retail trade sector. The approach to energy flexibility is holistic, considering indoor air quality, advanced control of indoor climate and lighting, energy consumption and supply, energy storage, use of waste heat and also user requirements, behavior and potential barriers.[8]

The main aim of this paper is to lay the ground work for a dynamic control-oriented model of a shopping center and to propose a preliminary control design in order to reduce energy consumption. Choosing a control-oriented modeling paradigm depends on the characteristics of the building in question, but for large-scale multi-zone buildings, a grey-box RC-equivalent approach is often applicable[9]. This is the approach taken in this paper.

The multi-zone model proposed in this paper, is applied to a small section of a Danish shopping center; this is done using both measurement data and table look-up of thermal parameters. With a model in place, a preliminary control design is proposed. The design seeks to increase energy efficiency, by utilizing a higher forward temperature in the shopping center cooling system. The design is evaluated through simulations.

In **Section II**, the shopping center in question is accounted for and following, in **Section III**, the model equations are introduced. With model equations introduced, the model is applied and parameters are identified in **Section IV**. **Section V** describes the preliminary control design and **Section VI** presents results from a simulation experiment using the proposed controller. Conclusions are given in **Section VII**.

Notation-wise, matrices are denoted in uppercase bold, e.g.  $\mathbf{A}$ , vectors are denoted in lowercase bold, e.g.  $\mathbf{x}$ . Dependence of variables on time  $t$ ,  $\mathbf{x}(t)$ , is implied and will not be written explicitly.

## II. SYSTEM DESCRIPTION

As a case for this paper, Kolding Storcenter in Jutland, Denmark, is considered. In Kolding Storcenter, a demo-area has been established for the SEBUT project. The demo-area considers a small cluster of three shops and the Central Cooling Unit (CCU) responsible for these shops. In Kolding Storcenter, cooling is delivered through a fan coil unit in the shops. The CCU delivers its cooling capacity through cooled water supplied to the fan coils. A shop-local controller regulates the supply air temperature to the shop, by actuating a valve that determines the flow of cold water through the fan coil. A block diagram depicting the demo-area setup is shown in **Figure 1**. For each shop, the room temperature,  $T_{shop}$ , and the supply temperature,  $T_{supply}$ , are measurable and the valve control signal,  $u_{valve}$  is available as input.

The current control solution consists of a shop-local controller, manipulating valve opening to regulate room temperature. This is done through the cascade PI configuration depicted in **Figure 2**. The temperature of the cooled water supplied to the fan coil,  $T_{fwd}$ , is controlled independently of the cooling requirements of the shops. This was concluded by investigating the Supervisory Control and Data Acquisition (SCADA) system in Kolding Storcenter.

Measurements were collected directly from the SCADA system. In **Figure 3**, shop temperature, supply temperature and valve opening is depicted, for one of the shops in the demo-area, over two days in May 2018 with summer-like weather conditions. Opening hours are from 10:00 to 20:00 and night-setback is implemented for the shop-local controllers.

From the measurements, it is clear that shop temperature rises throughout the day, indicating that there may be capacity problems in the system. Looking at the supply temperature; it is maintained at 14 °C without saturating the valve opening (for the most parts). From the SCADA system it was identified, that 14 °C is the minimum allowable supply temperature.

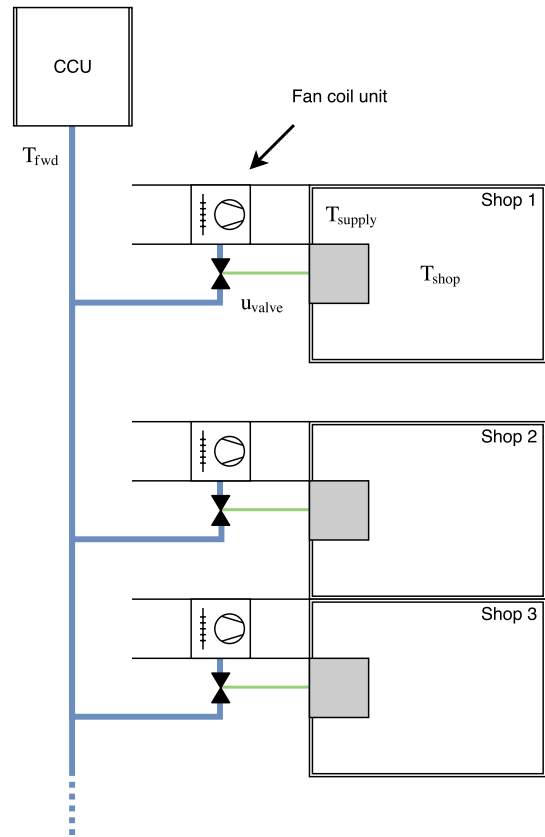

Fig. 1. System layout of demo-area, depicting the three shops and the CCU. Shop 1 is intentionally not adjacent to Shop 2 and Shop 3, as a hallway separates them. The return flow is not depicted in this diagram.

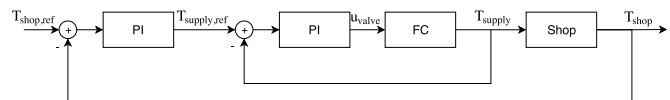

Fig. 2. The shop-local controller is two PI regulators in a cascade configuration. The FC block is the fan coil unit.

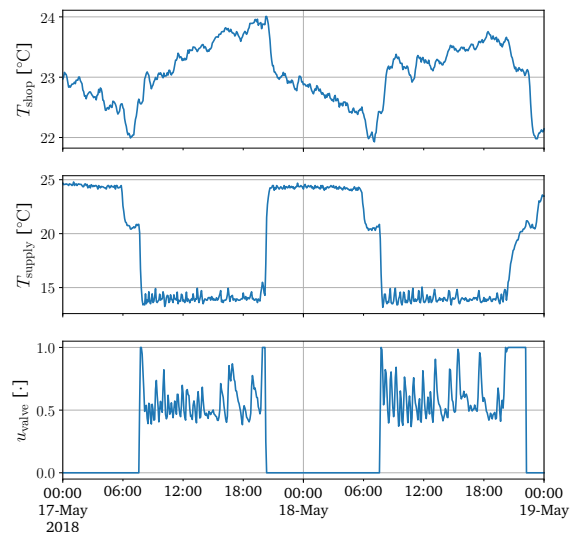

Fig. 3. Initial measurements from the demo-area in Kolding Storcenter. Shop temperature, supply temperature and valve opening for Shop 1 in the demo-area.

### III. MODEL

The purpose of the model is to capture the most important dynamics in order to design control strategies that can significantly improve energy efficiency. Since the potential is to consider entire shopping malls, the model also has to be scalable. The model will consider the central cooling, the fan coil units, the shops and hallways/common area separating the shops. Heat flows into a thermal zone are positive, while heat flows leaving a thermal zone are negative. The system is structurally very similar to the one in [10], which has served as inspiration.

#### A. Shop temperature model

At first we consider the thermal dynamics of a single shop:

$$C_{\text{shop},i} \dot{T}_{\text{shop},i} = \dot{Q}_{\text{adjacent},i} - \dot{Q}_{\text{fancoil},i} + \dot{Q}_{\text{int},i} \quad (1)$$

where  $C_{\text{shop},i}$  is the lumped thermal capacitance of the shop,  $T_{\text{shop},i}$  is the room temperature of the shop and  $\dot{Q}_{\text{adjacent},i}$  is the heat flow to/from surrounding shops and or hallways/common area – commonly denoted zones.  $\dot{Q}_{\text{fancoil},i}$  is the heat flow removed by the fan coil unit and  $\dot{Q}_{\text{int},i}$  models the internal heat gain, e.g. heat gain from occupancy, lighting and appliances.

Similarly, we consider the thermal dynamics of hallways/common area:

$$C_{\text{hall},i} \dot{T}_{\text{hall},i} = \dot{Q}_{\text{adjacent},i} + \dot{Q}_{\text{int},i} \quad (2)$$

where  $C_{\text{hall},i}$  is the lumped thermal capacitance of the hallway and  $T_{\text{hall},i}$  is the room temperature in the hallway. Equivalently to the shop dynamics, there is a term for heat flow to/from the adjacent zones and from internal heat gain. The main difference is that for hallways we do not model cooling, as the focus is on the shops.

The thermal dynamics of the fan coils are governed by the following state equation:

$$C_{\text{fancoil},i} \dot{T}_{\text{supply},i} = \dot{Q}_{\text{fancoil},i} - \dot{Q}_{\text{CCU},i} \quad (3)$$

where  $C_{\text{fancoil},i}$  is the lumped thermal capacitance of the fan coil unit and  $T_{\text{supply},i}$  is the temperature of the supply air to the shop, in which the fan coil unit is mounted. The heat flow to the fan coil is equivalent to the heat flow removed from the shop,  $\dot{Q}_{\text{fancoil},i}$ , and  $\dot{Q}_{\text{CCU},i}$  is the heat flow removed from the fan coil, by the supplied cold water from the CCU.

To model the heat exchange between adjacent zones, we consider a thermal resistance between the zones. This lets us write  $\dot{Q}_{\text{adjacent},i}$  as:

$$\dot{Q}_{\text{adjacent},i} = \sum_{j \in \mathcal{N}_i} \frac{T_j - T_i}{R_{i,j}} \quad (4)$$

where  $\mathcal{N}_i$  is the set of all neighboring zones and  $R_{i,j}$  is the thermal resistance between the zone in question,  $i$ , and its  $j$ -th adjacent neighbor.

We model the remaining heat flows as:

$$\dot{Q}_{\text{fancoil},i} = \dot{m}_{\text{air},i} c_{p,\text{air}} (T_{\text{supply},i} - T_{\text{shop},i}) \quad (5)$$

$$\dot{Q}_{\text{CCU},i} = \dot{m}_{\text{water},i} c_{p,\text{water}} (T_{\text{fwd}} - T_{\text{supply},i}) \quad (6)$$

where  $\dot{m}_{\text{air},i}$  is a fixed parameter, as the fan speed is not controllable. Specific heat capacity for air and water is given by  $c_{p,\text{medium}}$ . The flow of water,  $\dot{m}_{\text{water},i}$  is controllable through a valve. The pressure difference is assumed constant, together with the density of the refrigerant (water, no phase change). The valve characteristics are modeled to be linear:

$$\dot{m}_{\text{water},i} = K u_{\text{valve},i} \quad (7)$$

Assuming a linear valve characteristic is for this model acceptable for two apparent reasons; (1) we have no information on the actual characteristics and (2) the valve opening is controlled by a regulator.

The dynamics of  $T_{\text{fwd}}$  are not modeled, it is simply left as an input.

#### B. Scalability considerations

Now, the above state equations are in a suitable form when considering a low number of zones, but not for modeling an entire shopping mall, with the potential of hundreds of zones. Thus, the equations have been simplified through a graph theoretical view. We collect all the thermal zones, shops and hallways, as nodes in the graph  $\mathcal{G} = (\mathcal{N}, \mathcal{E})$ . An edge between two zones exists if they are physically adjacent. Furthermore, we let the edges be weighted by  $G_{i,j} = 1/R_{i,j}$  – the thermal conductance between the zones. Now, we form the adjacency matrix:

$$\mathbf{A}(\mathcal{G}) = [a_{i,j}] = [G_{i,j}] \in \mathbb{R}^{N_{\text{zones}} \times N_{\text{zones}}} \quad (8)$$

where  $G_{i,j} \neq 0$  if zone  $i$  and  $j$  are adjacent. Furthermore, let  $d(i) = \sum_j G_{i,j}$  denote the degree of the  $i$ -th node and let  $\mathbf{D}(\mathcal{G}) = \text{diag}(d(i))$ , then we can form the Laplacian matrix of  $\mathcal{G}$  as:

$$\mathbf{Q}(\mathcal{G}) = \mathbf{D}(\mathcal{G}) - \mathbf{A}(\mathcal{G}) \quad (9)$$

We can now express the vector of heat flows between zones as:

$$\dot{\mathbf{Q}}_{\text{adjacent}} = -\mathbf{Q}(\mathcal{G}) \mathbf{T} \quad (10)$$

$$\mathbf{T} = [\mathbf{T}_{\text{shop}} \quad \mathbf{T}_{\text{hall}}]^T \quad (11)$$

where  $\mathbf{T}_{\text{shop}} \in \mathbb{R}^{N_{\text{shops}}}$  and  $\mathbf{T}_{\text{hall}} \in \mathbb{R}^{N_{\text{halls}}}$  are the vectors collecting all the shop temperatures and hall temperatures, respectively. With this result, we can reduce our state equations to:

$$\mathbf{C} \dot{\mathbf{T}} = -\mathbf{Q}(\mathcal{G}) \mathbf{T} - \dot{\mathbf{Q}}_{\text{cool}} + \dot{\mathbf{Q}}_{\text{int}} \quad (12)$$

$$\dot{\mathbf{Q}}_{\text{cool}} = [\dot{\mathbf{Q}}_{\text{fancoil}} \quad \mathbf{0}]^T \quad (13)$$

$$\dot{\mathbf{Q}}_{\text{fancoil}} = \dot{\mathbf{m}}_{\text{air}} c_{p,\text{air}} (\mathbf{T}_{\text{supply}} - \mathbf{T}_{\text{shop}}) \quad (14)$$

$$\mathbf{C}_{\text{fancoil}} \dot{\mathbf{T}}_{\text{supply}} = \dot{\mathbf{Q}}_{\text{fancoil}} - \dot{\mathbf{Q}}_{\text{CCU}} \quad (15)$$

where  $\mathbf{C}$  is a diagonal matrix with  $C_{\text{shop},i}$  and  $C_{\text{hall},i}$  in the diagonal.  $\dot{\mathbf{Q}}_{\text{cool}}$  encapsulates  $\dot{\mathbf{Q}}_{\text{fancoil}}$ , which also handles potential cooling of the hallway. This is not considered in this model, however.

#### IV. MODEL APPLIED TO DEMO-AREA

Parameters have been estimated using table-lookup[9] and measurement data through manual fitting, comparing temperature responses from simulations<sup>1</sup> to the measured temperatures. The simulations are closed loop simulations, simulating the supply temperature control implemented in Kolding Storcenter. The resulting comparison between simulated model and measurements is given in **Figure 5**.

The desire is not a very accurate high-fidelity model, and as such the goal has simply been to find a parameter set which lies within the correct order of magnitude. The process was completed for a single shop, *Shop 1*, until a satisfactory fit was obtained. These parameters have then been scaled for *Shop 2* and *Shop 3*, given the shop sizes.

The floor plan for the demo-area is depicted in **Figure 4**, with the graph  $\mathcal{G}$  of thermal zones imposed on top. As *Shop 1* is large, it has been divided into two thermal zones. *Shop 2* and *Shop 3* are given a single thermal zone. The hallway area, separating *Shop 1* from *Shop 2* and *Shop 3* has been discretized to include seven thermal zones. *Shop 1* measures approximately 1000 m<sup>2</sup>, divided equally in the two thermal zones. *Shop 2* and *Shop 3* both measure approximately 250 m<sup>2</sup>.

Flow measurements of fan coils have been conducted, giving an approximate total mass flow for *Shop 1* of 513 kg/s;  $\dot{m}_{\text{air}} = 1.5 \text{ kg/s}$  for each zone in *Shop 1*. Under peak cooling conditions with a supply temperature of 14 °C and a shop temperature of 23 °C, this gives a cooling capacity of 27 kW. This indicates, that the internal heat gain,  $\dot{Q}_{\text{int}}$ , lies within this size. The shop temperature is, given the measurements obtained (**Figure 3**), largely dominated by  $\dot{Q}_{\text{int}}$  which based on observations at Kolding Storcenter, is due to lighting. Thus, for simulations  $\dot{Q}_{\text{int}}$  is introduced as a step from 0 W to 27 kW; 13.5 kW for each of the two zones.

To be able to deliver this cooling capacity, the valve characteristic constant has been chosen as  $K = 1.125$ ; this balances the system in peak cooling conditions, delivering 14 °C supply temperature at a valve opening of 0.5, assuming a CCU forward temperature reference of  $\approx 8 \text{ °C}$ , which was identified from the SCADA system at Kolding Storcenter. No data of the forward temperature is however available from the same period as the rest of the measurements.

Thermal capacitances were obtained using table lookup and an estimate of shop volume. Thermal resistances were obtained through estimating the area of either open facades or interior walls between adjacent zones. The thermal conductance between the hallway zones and shop zones was set as 100 W/K, as was the thermal conductance between hallway zones in-between. This is justified by the large open facades of the shops. The conductance between *Shop 2* and *Shop 3* was set as 50 W/K.

Given the results in **Figure 5**, the model fits measurements to an acceptable degree, given the limited information and the simplified parameter identification process.

<sup>1</sup>A simulation environment has been built in Python using SciPy[11].

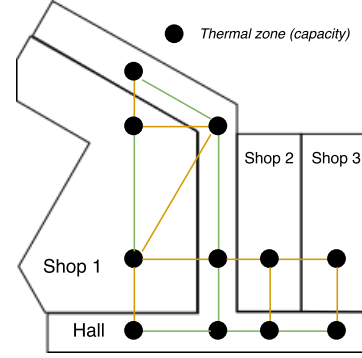

Fig. 4. Demo-area in Kolding Storcenter, with a graph of thermal zones imposed on top. The edges between the nodes (zones) determine the thermal interaction. The edges are colored to distinguish interaction between shops and hallway (orange) and hallways/shops in-between (green).

#### V. ENERGY OPTIMIZATION THROUGH CONTROL

A key aspect of the SEBUT project, is that the designed control solutions have to be applicable to already existing building setups, re-using as much as possible, in an attempt to keep the implementation minimal and the impact maximal. As such, this paper introduces a preliminary control solution, that does not alter the shop-local controllers. Instead, it is desirable to investigate the introduction of forward temperature setpoint scheduling.

One metric for energy efficiency in refrigeration systems is the Coefficient of Performance (COP), which can be expressed as:

$$\text{COP} = \frac{\dot{Q}_{\text{refrig}}}{P_c} \quad (16)$$

where  $\dot{Q}_{\text{refrig}}$  is the heat removed from the system by the refrigeration system and  $P_c$  is the power consumed by the refrigeration system. In our case:

$$\dot{Q}_{\text{refrig}} = \sum_i \dot{Q}_{\text{CCU},i} = \dot{m}_{\text{tot}} c_{p,\text{water}} (T_{\text{fwd}} - T_{\text{ret}}) \quad (17)$$

$$\dot{m}_{\text{tot}} = \sum_i \dot{m}_i \quad (18)$$

$$T_{\text{ret}} = \frac{\sum_i \dot{m}_i T_{\text{supply},i}}{\sum_i \dot{m}_i} \quad (19)$$

The theoretical COP of the CCU is dependent on forward temperature and ambient temperature (heat reservoir), as given by the COP for a Carnot cycle:

$$\text{COP}_{\text{max}} = \frac{T_{\text{fwd}}}{T_{\text{amb}} - T_{\text{fwd}}} \quad (20)$$

Thus, the efficiency increases, as the forward temperature approaches the ambient temperature. This is a crude simplification for a chiller, but it reveals a desire to let the forward temperature be as close to the ambient temperature, while still enabling the cooling capacity demand by the fan coil units. This expression for  $\text{COP}_{\text{max}}$  is however only valid in the case where ambient temperature is higher than the temperature inside, limiting it to cooling of the shops during the summer. In the case where the ambient temperature is

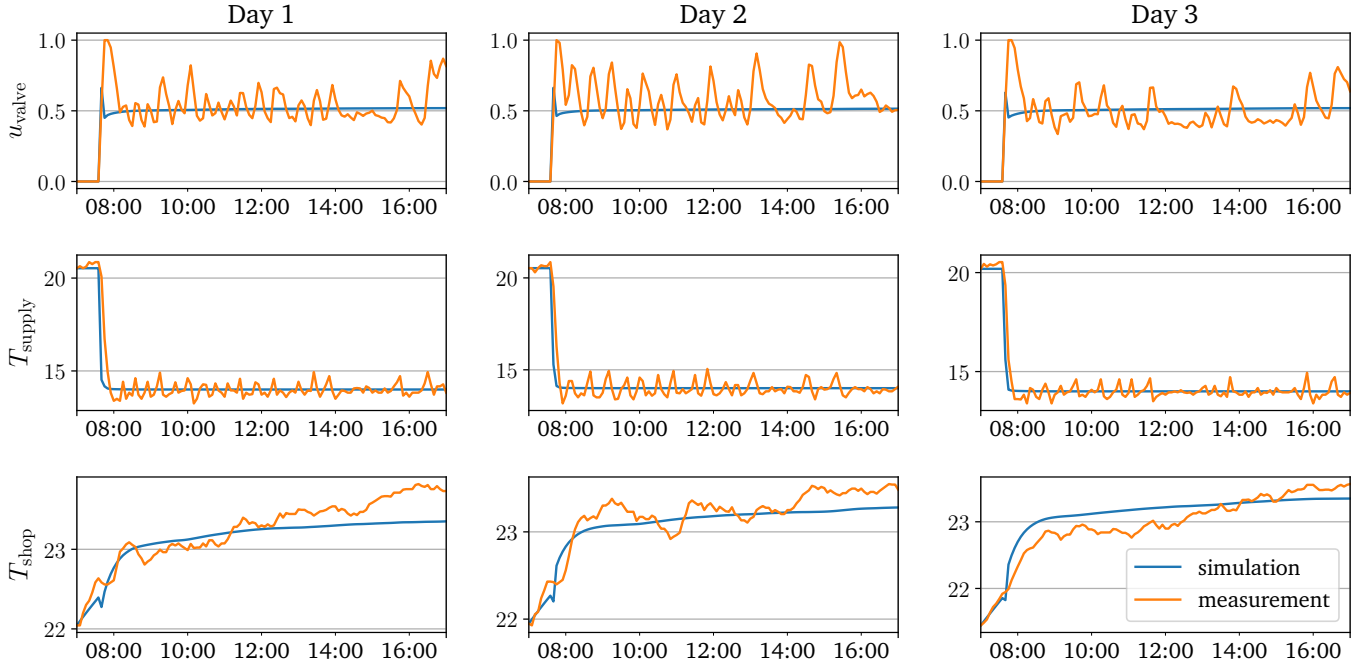

Fig. 5. Comparison between simulated model with identified parameters and measured data, across three different days (2018-05-17, 2018-05-18, 2018-05-23) with summer conditions. Generally a good fit. The biggest uncertainty lies in shop temperature; since this is not actively controlled as the supply temperature and given the many disturbances not known in e.g.  $Q_{\text{int}}$ .

lower than the inside temperature, there is no theoretical limit on  $\text{COP}_{\text{max}}$ . This implies that (20) will eventually have to be replaced by a combined expression that takes both cooling and heating into account. That is beyond the scope of the preliminary work in the present paper, however.

This paper proposes a centralized control solution, regulating the forward temperature such that the fan coil unit with the highest cooling demand, has its valve opening almost saturate (90% open), leaving some headroom for disturbance rejection. This approach is similar to the one taken in [12]. The control solution is depicted in **Figure 6**.

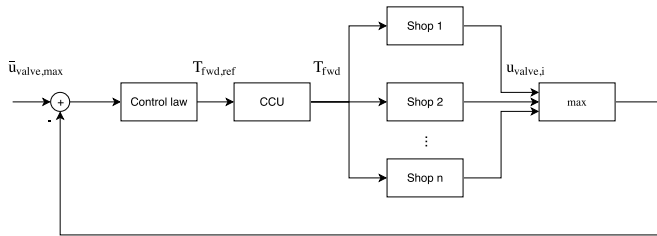

Fig. 6. Control solution to drive valve opening close to saturation, through regulation of forward temperature.

The benefits of this control solution is especially the low barriers to implementation, as the shop-local controllers remain untouched. The controller is in this paper a regular PI controller, giving rise to the control law:

$$e = \bar{u}_{\text{valve,max}} - \max(\mathbf{u}_{\text{valve}}) \quad (21)$$

$$T_{\text{fwd,ref}} = K_p e + K_i \int e dt \quad (22)$$

where  $\max$  is the operation that picks out the maximum element in the vector given, and  $\bar{u}_{\text{valve,max}} = 0.9$ . The  $\max$  operation introduces switching-behavior to the system. Stability-wise, this can be analyzed using standard hybrid system analysis[13], but such an analysis is not within the scope of this paper.

## VI. SIMULATION STUDIES

A simulation has been carried out to investigate the difference between a constant forward temperature and controlling the forward temperature, through the suggested control strategy. The simulation mimics the daily behavior of the system, just as for the parameter estimation simulations. The only two differences being that at 11:00, the otherwise constant forward temperature of cold water is instead regulated using the scheme described in **Section V** – and that measurement noise is modeled for the supply temperature, to introduce a stochastic element in the simulation. The measurement noise is sampled from a normal distribution with  $\mu = 0$  and  $\sigma = 0.05$ , which is the approximate noise level identified in the measurement data. The results of the simulation are depicted in **Figure 7**.

It should be noted, that the local PI controllers maintain the shop temperatures at the references, even with the central forward temperature control enabled. The forward temperature is raised from the  $8^\circ\text{C}$  to around  $10^\circ\text{C}$ , which could be a significant efficiency increase, especially given the peak cooling conditions – this is also indicated by the increase in the maximum COP.

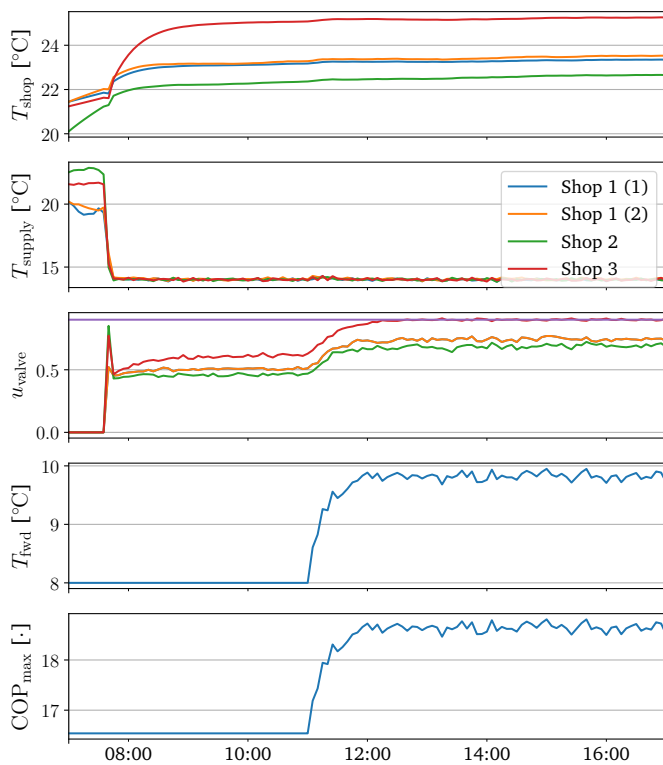

Fig. 7. Simulation comparing the effects of a constant forward temperature with the proposed control solution, driving valve opening towards (almost) full opening. The purple line shows the valve opening reference of 0.9.  $COP_{max}$  is calculated assuming  $T_{amb}$  of 25 °C.

## VII. CONCLUSIONS

This paper has laid the ground work for a dynamical model of a shopping center. It has proposed a scalable multi-zone model and applied it to a demo area in a danish shopping center; estimating parameters through measurement data and table-lookup with acceptable results.

Using the model, a preliminary control design was proposed to allow the system to run using higher forward temperatures, for better energy efficiency. Through simulations, the design shows promising results; most importantly given the low implementation barriers. The simulation presented in this paper showed, that the introduction of this central controller would not degrade the performance of the shop-local controllers, allowing a gain in energy efficiency through a relatively simple central implementation.

Future work includes collecting data on power consumption, to pose an operational model of COP. This will allow conclusions to be drawn on the energy efficiency improvements of the control scheme proposed. Also, it is necessary to further investigate both scalability of the model – especially in regards to the inclusion of hallway zones – but also flexibility, as the desire is to reuse the framework for different shopping centers.

## ACKNOWLEDGMENT

This research is funded by the SEBUT project under ForsKEI/EUDP grant no. 2016-1-12555.

## REFERENCES

- [1] International Energy Agency. *Energy Policies of IEA Countries - Denmark 2017 Review*. Tech. rep. 2017.
- [2] Pervez Hameed Shaikh et al. “A review on optimized control systems for building energy and comfort management of smart sustainable buildings”. In: *Renewable and Sustainable Energy Reviews* 34 (2014), pp. 409–429.
- [3] Vikas Chandan and Andrew G. Alleyne. “Decentralized predictive thermal control for buildings”. In: *Journal of Process Control* 24.6 (2014), pp. 820–835. ISSN: 09591524. DOI: 10.1016/j.jprocont.2014.02.015.
- [4] Jie Cai et al. “A general multi-agent control approach for building energy system optimization”. In: *Energy and Buildings* 127 (2016), pp. 337–351. ISSN: 03787788. DOI: 10.1016/j.enbuild.2016.05.040.
- [5] Yudong Ma, Garrett Anderson, and Francesco Borrelli. “A Distributed Predictive Control Approach to Building Temperature Regulation”. In: *American Control Conference*. 2011, pp. 2089–2094. ISBN: 9781457700811. DOI: 10.1109/ACC.2011.5991549.
- [6] Petru Daniel Morosan et al. *Distributed MPC for multi-zone temperature regulation with coupled constraints*. Vol. 18. PART 1. IFAC, 2011, pp. 1552–1557. ISBN: 9783902661937. DOI: 10.3182/20110828-6-IT-1002.00516.
- [7] Nikitha Radhakrishnan et al. “Token based scheduling for energy management in building HVAC systems”. In: *Applied Energy* 173 (2016), pp. 67–79. ISSN: 03062619. DOI: 10.1016/j.apenergy.2016.04.023.
- [8] SEBUT. *SEBUT*. URL: <http://sebut.teknologisk.dk/> (visited on 01/02/2018).
- [9] Ercan Atam and Lieve Helsens. “Control-Oriented Thermal Modeling of Multizone Buildings: Methods and Issues: Intelligent Control of a Building System”. In: *IEEE Control Systems* 36.3 (2016), pp. 86–111. ISSN: 1066033X. DOI: 10.1109/MCS.2016.2535913.
- [10] Michael Hansen, Jakob Stoustrup, and Jan Dimon Bendtsen. *Modeling of nonlinear marine cooling systems with closed circuit flow*. Vol. 18. PART 1. IFAC, 2011, pp. 5537–5542. ISBN: 9783902661937. DOI: 10.3182/20110828-6-IT-1002.01947.
- [11] Eric Jones, Travis Oliphant, Pearu Peterson, et al. *SciPy: Open source scientific tools for Python*. 2018. URL: <http://www.scipy.org/> (visited on 01/02/2018).
- [12] Fatemeh Tahersima et al. “Economic COP optimization of a heat pump with hierarchical model predictive control”. In: *2012 IEEE 51st IEEE Conference on Decision and Control (CDC)* (2012), pp. 7583–7588. ISSN: 01912216. DOI: 10.1109/CDC.2012.6425810.
- [13] M.S. Branicky. “Multiple Lyapunov functions and other analysis tools for switched and hybrid systems”. In: *IEEE Transactions on Automatic Control* 43.4 (1998), pp. 475–482. ISSN: 00189286. DOI: 10.1109/9.664150. URL: <http://ieeexplore.ieee.org/document/664150/>.